

It has come to our attention that some of the newer, cost-effective broadcast accessories do not support the traditional audio program signal levels common to the analog side of the plant. For example, a very popular streaming codec cannot accept or deliver a program signal greater than 5V p-p, yet traditional “plus four” program sources can have excursions that reach 22V p-p.

Inovonics is pledged to embrace traditional values when it comes to audio program signals. This means that some of our products that do not have output level controls can create an issue when interfacing with restricted-level inputs.

Fortunately there is an easy fix. A good number of our products have an electronically-balanced output stage that looks like this:

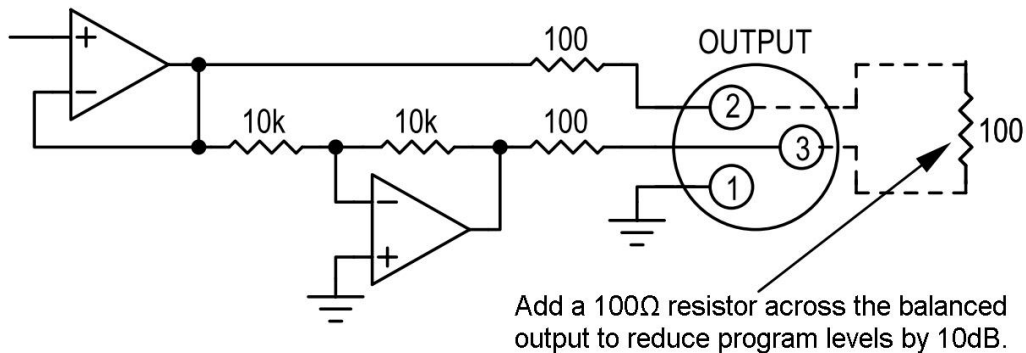

An unloaded “plus four” test tone will measure +4dBu across the balanced output, or –2dBu, unbalanced, from either output terminal to ground. We can exploit the native 200-ohm source impedance of this circuit and simply load the balanced output (pin 2 to pin 3) with a 100-ohm resistor. Now the balanced output will measure –6dBu, and an unbalanced output (either pin 2 or pin 3 to ground) will read –12dBu. This makes the unbalanced output much more signal-friendly to sound cards and similar computer-age devices.